

HORIBA

Process & Environmental

Explosion-proof INFRARED ANALYZER

EIA-51d/51p
TIA-51d/51p

Explosion-proof THERMAL CONDUCTIVITY ANALYZER

TCA-51d/51p

Explosion-proof MAGNETOPNEUMATIC OXYGEN ANALYZER

MPA-51d/51p

Explosion-proof PARAMAGNETIC OXYGEN ANALYZER

PMA-51d



Advanced technologies that provide safety. An explosion-proof gas analyzer is born.

The 51 series advanced explosion-proof analyzers include HORIBA's extensive experience and specialized know-how to provide the safety, reliability, and accuracy you demand in analyzing flammable gases or operating in explosive environments. To realize the highest levels of safety and operability, the 51 series offers an intuitive interface with a clearly visible display. The analyzers' long term reliability and your confidence are ensured by full compatibility with IEC 60079 standards. The extensive line-up for the 51 series covers a wide range of applications including infrared gas analyzers for general-purpose processes and models for use with oxygen and hydrogen. The HORIBA 51 series meets your gas analysis needs in environments where safety, reliability, and accuracy are always your priorities.



New designs and unique concepts define the next generation of standards

Focused on functionality

- **Meets diverse gas analysis requirements**
- **Offers a clearly visible and easy-to-operate user interface**
- **Compatible with IEC 60079 standards and communication functions**

Hydrogen explosion-proof models

Building on the HORIBA legacy of safety, reliability, and accuracy of the 31 series, the new 51 series enhances explosion-proof specs to the level of IIB + H₂.

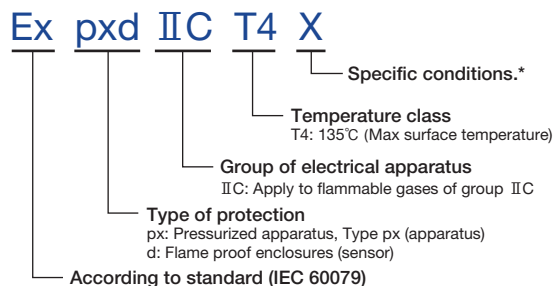
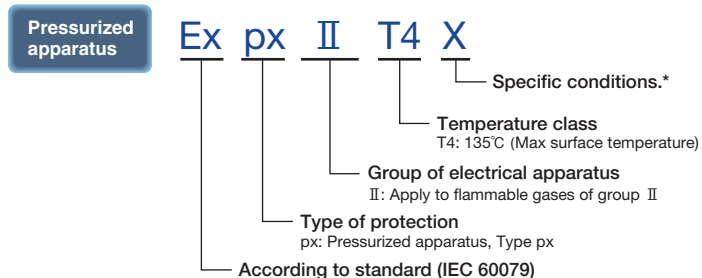
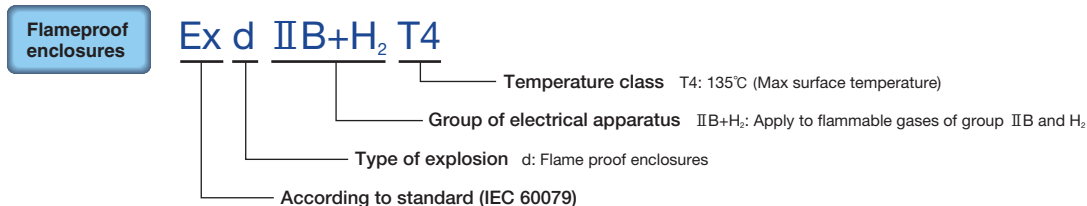

*The apparatus pressurized internally is 50 Pa higher than measuring gas pressure.

Principle

EIA-51d/51p · TIA-51d/51p

■ Non-dispersive infrared (NDIR) analyzer (interference correction type)

Conceptual diagram

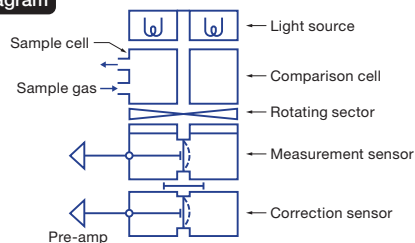

Measurement principle

"Interference correction" is an original method based on NDIR analysis that ensures extremely high accuracy even in the case of samples containing large amounts of interfering compounds.

The interference correction combines a measurement sensor with a correction sensor positioned in parallel in the same optical path. This significantly reduces the effects of:

- interfering gases in the sample gas;
- vibrations and other external disturbances; and
- drift resulting from deterioration of the light source and cell components.

TCA-51d/51p

■ Heat conductivity type

Conceptual diagram

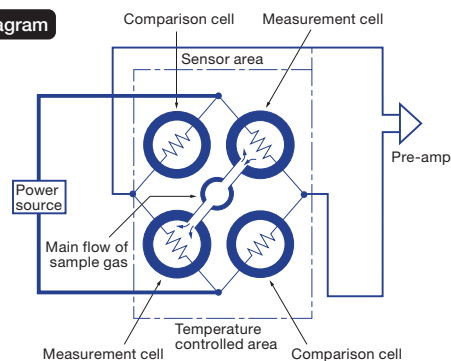

Measurement principle

Gas concentration is measured using the differences in heat conductivity unique to specific gases. The sensor area forms a Wheatstone bridge using measurement cells and comparison cells containing hot wires made from platinum and other materials. The sample gas flows into the measurement cell as a result of diffusion, and a base gas (generally nitrogen or air) is sealed inside the comparison cell.

The hot wires are heated by a constant current. If the sample gas contains a gas with a heat conductivity differing from that of the standard gas in the comparison side, then the temperature of the hot wires on the measurement side changes, and this in turn changes the resistance depending on the composition of the sample gas. This change in resistance is converted into a concentration signal for the gas being measured, based on the change in the unbalanced voltage of the Wheatstone bridge.

MPA-51d/51p

■ Magnetic pressure analyzer (pressure sensor / magnetic force type)

Conceptual diagram

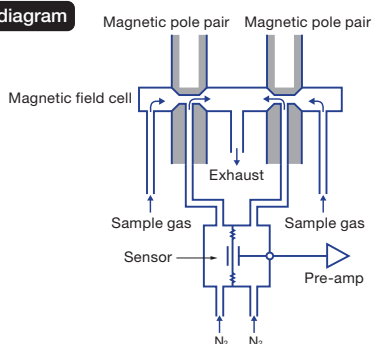

Measurement principle

Because oxygen has extremely strong paramagnetic characteristics, if there is any oxygen in a heterogeneous magnetic field, then the oxygen is drawn toward the stronger magnetic field, and the pressure in that area changes (increases).

The change in pressure is represented by the following formula.

$$\Delta p = 1/2 H^2 \times X \times C$$

Δp : change in pressure; H: Strength of magnetic field; X: Magnetic susceptibility of paramagnetic gas; C: Temperature of paramagnetic gas

This pressure increase is drawn out of the magnetic field using a non-magnetic comparison gas (nitrogen), and the pressure change is detected by a sensor and converted into an electrical signal. The electromagnets are excited alternately to derive and transmit a stable signal, which is processed as an alternating signal. For this reason, if there is no oxygen in the sample gas, the signal is zero, so there is no zero drift, and the signal remains extremely stable over long periods of time. Furthermore, the output is linear in reference to the oxygen concentration, so concentration can be measured across a very broad range.

PMA-51d

■ Magnetic dumbbell (dumbbell-shaped magnet type)

Conceptual diagram

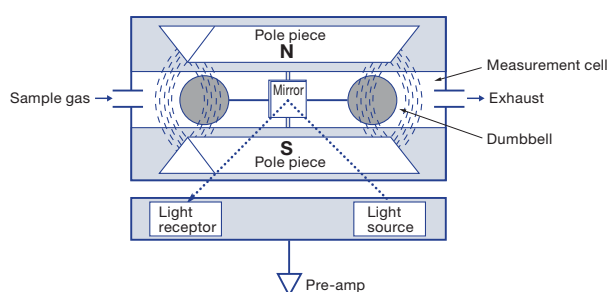

Measurement principle

Because oxygen has extremely strong paramagnetic characteristics, if there is any oxygen in a heterogeneous magnetic field, then the oxygen is drawn toward the stronger magnetic field.

In the sensor area, a glass dumbbell with a mirror attached is hung horizontally using platinum wires. When oxygen passes through the sensor area, the dumbbell is pushed out by the magnetic field effects described above.

The change in pressure is represented by the following formula.

$$F = (X1 - X2) \times V \times H$$

F: Force acting on the dumbbell; X1: Magnetic susceptibility of the dumbbell; X2: Magnetic susceptibility of the surrounding gas; V: Volume of the test body; H: Strength of the magnetic field

As the dumbbell rotates, the position of the reflected light reaching the photocell (the light receptor) changes. Reverse torque is then added to the dumbbell through a feedback system to return the dumbbell to its original position.

Because this torque is linear in reference to the oxygen concentration, the torque value is output as the oxygen concentration.

■ Specification

Model		EIA-51d	EIA-51p	TIA-51d	TIA-51p	
Type of protection		Exd II B+H ₂ T4	Exp II T4X	Exd II B+H ₂ T4	Exp II T4X	
Flameproof enclosures		●		●		
Pressurized apparatus			●		●	
Measurement method		NDIR				
Component		CO, CO ₂ , CH ₄ , etc.*1				
Measurement range	Minimum range	0 to 0.11 vol% (Depends on the component)		0 to 50 ppm (Depends on the component)		
	Maximum range	0 to 100 vol% (Depends on the component)		0 to 2000 ppm (Depends on the component)		
	Optional	100-90 to 50 vol% (Depends on the component)		0-20 to within less than 50 ppm (Depends on the component)	—	
Range Ratio		—		—		
Performance	Repeatability	Standard range	Zero : ±0.5% of full scale		Zero : ±0.5% of full scale	
		Optional range	Span : ±0.5% of full scale		Span : ±0.5% of full scale	
	Linearity	Zero : ±0.5% of full scale		Zero : ±1.0% of full scale		
		Span : ±0.5% of full scale		Span : ±1.0% of full scale		
	Drift*2	Standard range	Zero : ±2.0% of full scale/week		Span : ±2.0% of full scale/week	
		Optional range	—			
Response time		T90 within 20 seconds		T90 within 20 seconds T90 within 40 seconds (TIA optional range)		
Sample gas Condition	Gas composition	Flameproof enclosures	O ₂ : 21% or less, no mist, no dust The hazardous must be equivalent or less with electrical apparatus group II B, gas and vapor-air mixture corresponding to temperature code T4.			
		Pressurized apparatus	O ₂ : 21% or less, no mist, no dust The ignition temperature must be equivalent or less with electrical apparatus of gas and vapor-air mixture corresponding to temperature code T4.			
	Pressure		Over 1.98 kPa			
	Flow rate		Approx. 500 mL/min.			
	Temperature		Ambient temperature			
	Exhaust		Atmosphere pressure			
Materials in contact with sample gas		SUS304, SUS316, FKM, CaF ₂ , Au, etc.				
Calibration method		Standard : Manual correction, Option : Automatic correction				
Analog output			DC 4 to 20 mA (DC 0 to 16 mA/0 to 20 mA, DC0 to 1 V/0 to 5 V/1 to 5 V/0 to 10 V optional), 1 ch			
	Alarm setting		Arbitrary setting is available with span range from -10% to +110% of output for current and voltage. Negative output values set to 0.			
Contact Input-output (option)		6 channels				
Digital connection (option)	Interface		RS-485			
	Protocol		Modbus-RTU			
	Communication speed		Selected from 19200 bps/9600 bps/4800 bps/2400 bps/1200 bps			
Environment conditions	Location		Indoors			
	Operational Temperature		-5 to 40 °C (away from direct sunlight and radiant heat)			
	Humidity		90% or less			
	Vibration		Avoid large vibration sources (less than 100 Hz; 0.3 m/s ²)			
Utility	Protective gas for Pressurized apparatus composition		Gas composition : N ₂ , Gas pressure : 196 to 690 kPa, Gas flow rate : 10 L/min. (when purging), 500 mL/min. (when operating) De			

*1 Consult HORIBA for measurement of the other components. *2 Guaranteed at normal ambient temp. ±5°C

■ Recommended Measuring Ranges

	EIA-51d/51p		TIA-51d/51p	
	Min. Range	Max. Range	Min. Range	Max. Range
CO	0 to 0.21%	0 to 100%	0 to 500 ppm	0 to 2000 ppm
CO ₂	0 to 0.11%	0 to 100%	0 to 500 ppm	0 to 1000 ppm
CH ₄	0 to 0.21%	0 to 100%	0 to 500 ppm	0 to 2000 ppm
C ₃ H ₈	0 to 0.06%	0 to 100%	0 to 500 ppm	0 to 500 ppm
NO	0 to 0.21%	0 to 100%	0 to 100 ppm	0 to 2000 ppm
SO ₂	0 to 0.06%	0 to 100%	0 to 100 ppm	0 to 500 ppm

Consult HORIBA for applications other than those listed above.

TCA-51d	TCA-51p	MPA-51d	MPA-51p	PMA-51d
Exd II B+H ₂ T4	Expxd II T4X	Exd II B+H ₂ T4	Expx II T4X	Exd II B+H ₂ T4
●	●	●	●	●
Thermal conductivity		Magnetopneumatic		Paramagnetic
H ₂		O ₂		
0 to 10 vol%		0 to 5 vol%		
0 to 100 vol%		0 to 25 vol%		
0-1 to within less than 10 vol% 100-90 to 50 vol%		0-1 to within less than 5 vol%		—
—		Max.1:25 Max.4 range		Max.1: 5
Zero : ±1.0% of full scale		Zero : ±0.5% of full scale		Zero : ±0.1 vol% O ₂
Span : ±1.0% of full scale		Span : ±0.5% of full scale		Span : ±0.1 vol% O ₂
Zero : ±1.0% of full scale		Zero : ±1.0% of full scale		—
Span : ±1.0% of full scale		Span : ±1.0% of full scale		—
		Zero : ±1.0% of full scale/week		Zero : ±0.05 vol% O ₂ /week
		Span : ±2.0% of full scale/week		Span : ±0.05 vol% O ₂ /week
		Zero : ±1.0% of full scale/week		—
		Span : ±3.0% of full scale/week		—
T90 within 20 seconds				

Temperature code T4, and Hydrogen-air mixture.

O ₂ : 21% or less, no mist, no dust The hazardous must be equivalent or less with electrical apparatus of group II C gas and vapor-air mixture corresponding to temperature code T4.	O ₂ : 21% or less, no mist, no dust The ignition temperature must be equivalent or less with electrical apparatus of gas and vapor-air mixture corresponding to temperature code T4.
	14.7 to 24.5 kPa
	Approx . 1.5L/min
	Over 1.98 kPa
	Approx . 300mL/min
SUS304, SUS316, FKM, glass, SiO ₂ , Au	SUS304, SUS316, FKM
	SUS304, SUS316, Pt, glass, FKM

to zero.

Low Point : -30°C Saturated or less

System configuration

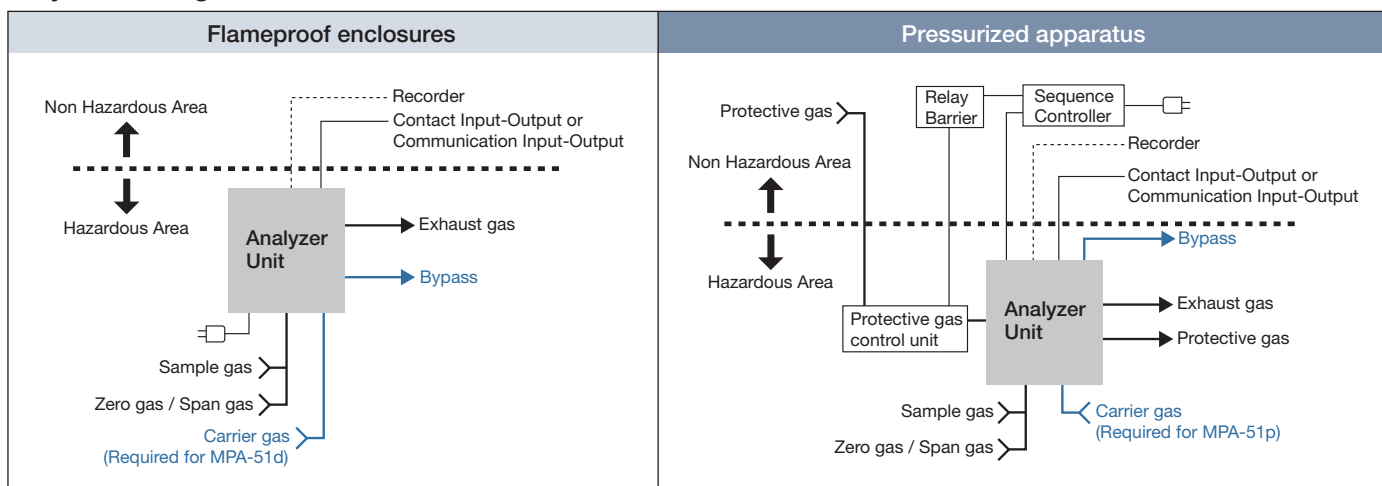

■ Dimensional Outlines unit: mm

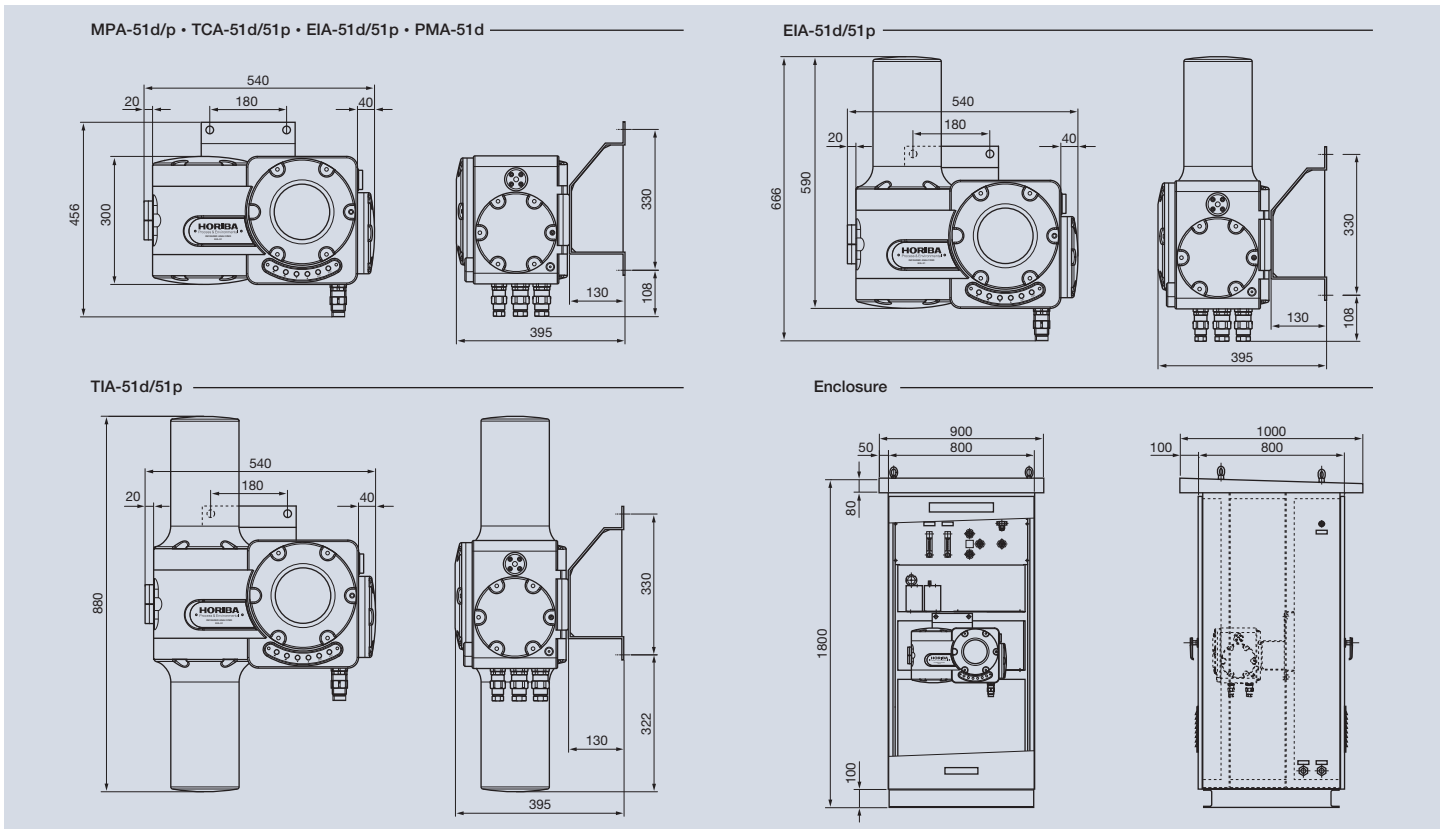

■ Peripheral instruments (Required for Pressurized apparatus)

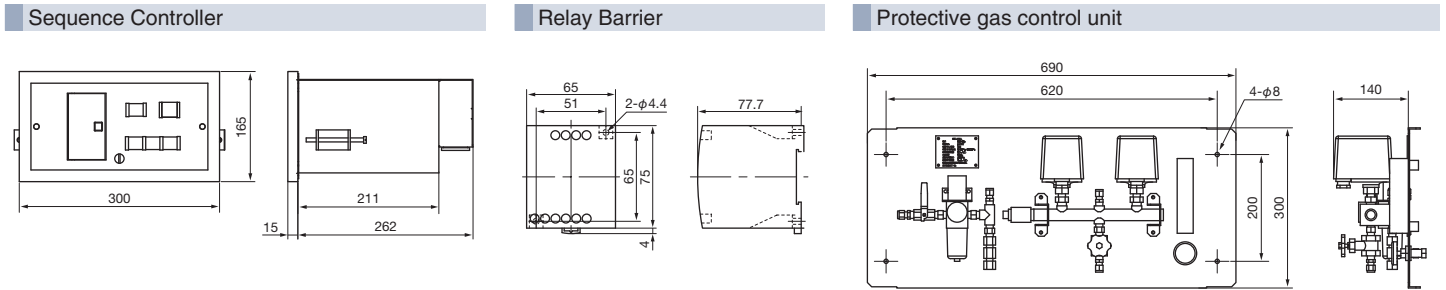

⚠ Please read the operation manual before using this product to assure safe and proper handling of the product.

- The contents of this catalog are subject to change without prior notice, and without any subsequent liability to this company.
- The color of the actual products may differ from the color pictured in this catalog due to printing limitations.
- It is strictly forbidden to copy the content of this catalog in part or in full.
- All brand names, product names and service names in this catalog are trademarks or registered trademarks of their respective companies.

<http://www.horiba.com> e-mail: info@horiba.co.jp

● HORIBA, Ltd.

Head Office
2 Miyano Higashi, Kisshoin
Minami-ku, Kyoto, Japan
Phone: 81 (75) 313-8123
Fax: 81 (75) 321-5725

Tokyo Sales Office
Kanda-Awaji-cho Nichome
Building 2-6, Awaji-cho,
Kanda, Chiyoda-ku, Tokyo,
Japan
Phone: 81 (3) 6206-4721
Fax: 81 (3) 6206-4730

● HORIBA (China) Trading Co., Ltd.

Shanghai Office
Room 1701, United Plaza,
1468 Nanjing Rd. West,
Shanghai, 200040, China
Phone: 86 (21) 6289-6060
Fax: 86 (21) 6289-5553

Beijing Office
Room 1801, SK Tower,
Tower 1 No.6Jia, Jianguomenwai Ave.,
Chaoyang District, Beijing,
100022 China
Phone: 86 (10) 8567-9966
Fax: 86 (10) 8567-9066

● HORIBA Korea Ltd.

112-6 Sogong-Dong
Choong-ku, Seoul, Korea
Phone: 82 (2) 753-7911
Fax: 82 (2) 756-4972

● HORIBA Instruments (Singapore) Pte Ltd.

Head Office
10 Ubi Crescent
Lobby B #05-12, Ubi
Techpark Singapore 408564
Phone: 65 6745-8300
Fax: 65 6745-8155

Hanoi Office
Unit 10, 4 Floor, CMC tower,
Dich Vong Hau Ward, Cau Giay
district, Hanoi, Vietnam
Phone: 84 (4) 3795-8552
Fax: 84 (4) 3795-8553

Jakarta Office
Jl. Jend. Gatot. Subroto,
Kav 71-73, Menara Bidakara 2,
Unit 11-04, Jakarta Selatan,
12870, Indonesia
Phone: 62 (21) 2906-9419
Fax: 62 (21) 2906-9421

● HORIBA India Private Limited

Delhi Office
246, Okhla Industrial Estate,
Phase 3 New Delhi - 110020,
India
Phone: 91 (11) 4646-5000
Fax: 91 (11) 4646-5020

Pune Office
502, Purushottam Plaza,
Baner Road, Baner,
Pune - 411045 India
Phone: 91 (20) 2729-1121
Fax: 91 (20) 2719-1121

● HORIBA Instruments Incorporated

Irvine North Office
17671 Armstrong Avenue
Irvine, CA 92614, U.S.A.
Phone: 1 (949) 250-4811
Fax: 1 (949) 250-0924

● HORIBA Instruments Limited

Kyoto Close
Summerhouse Road
Moulton Park, Northampton
NN3 6FL, UK
Phone: 44 (1604) 542-500
Fax: 44 (1604) 542-699

● HORIBA (Austria) GmbH

Kaplanstrasse 5
A-3430 Tulln,
Austria
Phone: 43 (2272) 65225
Fax: 43 (2272) 65230

HORIBA Czech
Organizacni slozka Praha
Petrohradská 13
CZ-101 00 Praha 10,
Czech Republic
Phone: 420 (2) 717-464-80
Fax: 420 (2) 717-470-64

● HORIBA Europe GmbH

Head Office
Hans-Mess-Str.6
D-61440 Oberursel
Germany
Phone: 49 (6172) 1396-0
Fax: 49 (6172) 1373-85

Leichlingen Office
Julius-kronenberg Str.9
D-42799 Leichlingen
Germany
Phone: 49 (2175) 8978-0
Fax: 49 (2175) 8978-50

● HORIBA France Sarl

12, Avenue des Tropiques
F-91955 LES ULIS
France
Phone: 33 (1) 69-29-96-23
Fax: 33 (1) 69-29-95-77