

## GENERAL PURPOSE GAS ANALYZERS

# 510Series

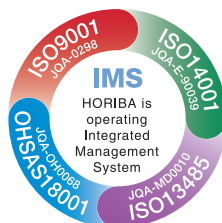

# A flexible response to the varied needs of gas analysis, from clean gas to flue gas.

There is a growing need for more comprehensive gas analysis in line with rising public concern over the effects of combustion exhaust gas on the global environment and the desire to conserve energy.

HORIBA has concentrated its years of technological know-how in the 510 series of general purpose gas analyzers built to suit an extensive range of applications.

The 510 series of components encompasses four different types of analyzers: the VIA-510 infrared analyzer, the MPA-510 O<sub>2</sub> analyzer, the CLA-510SS chemi-NO<sub>x</sub> analyzer, and the FIA-510 THC analyzer along with the special ES-510, ES-C510SS and ES-F510 sampling units for measuring dirty or wet gas. In addition, various measurement conditions can easily be set so as to allow a flexible response that meets the precise requirements for all sorts of application.

## Easy to operate

The 510 series is extremely easy to operate thanks to the built-in microprocessor. A digital display makes it possible to take direct readings of concentrations, and zero and span calibrations can be done at the touch of a button. The unit retains the sampling gas concentration valves during calibration with the HOLD function. It also has a self-diagnosis function, a full-scale limiter function, and an external range switching function.

## Selectable response time

The response time (electrical) T<sub>90</sub> can be set with a dip switch to match individual needs (3, 10, 30 seconds; set at 10 sec. when shipped).

## Compact components

The analyzer unit and the sampling unit are compact components that can be placed on a desk or mounted in a 19" rack. A wide range of layouts is possible to best match your needs.

## Wide range

For the VIA-510 and MPA-510, 4 ranges and a range ratio of 1:10 are standard; for the CLA-510SS and FIA-510, 7 ranges and a ratio of 1:100 are standard. Fullscale ranges can be set within the maximum and minimum ranges by the customer.

## Universal outputs

A variety of isolated outputs makes the 510 series compatible with any computer, recorder, etc. There are three parallel outputs: 0 to 1 V, 0 to 10 V, and 4 to 20 mA (or 0 to 16 mA). It is also possible to output self-diagnosis status, and signal hold status, calibration status, hold and range identification signals, remote hold and range switching commands are acceptable.

## Sampling units

Exclusive sampling units are available for measuring dirty and wet samples such as flue gas. Two types of general-purpose gas analyzer can be linked, and they can even be used by stacking one on top of the other.

VIA: Versatile Infrared Analyzer, MPA: Magneto Pneumatic Analyzer, CLA: Chemiluminescence Analyzer, FIA: Flame Ionization Analyzer

## Typical component layout to best satisfy your lab or process

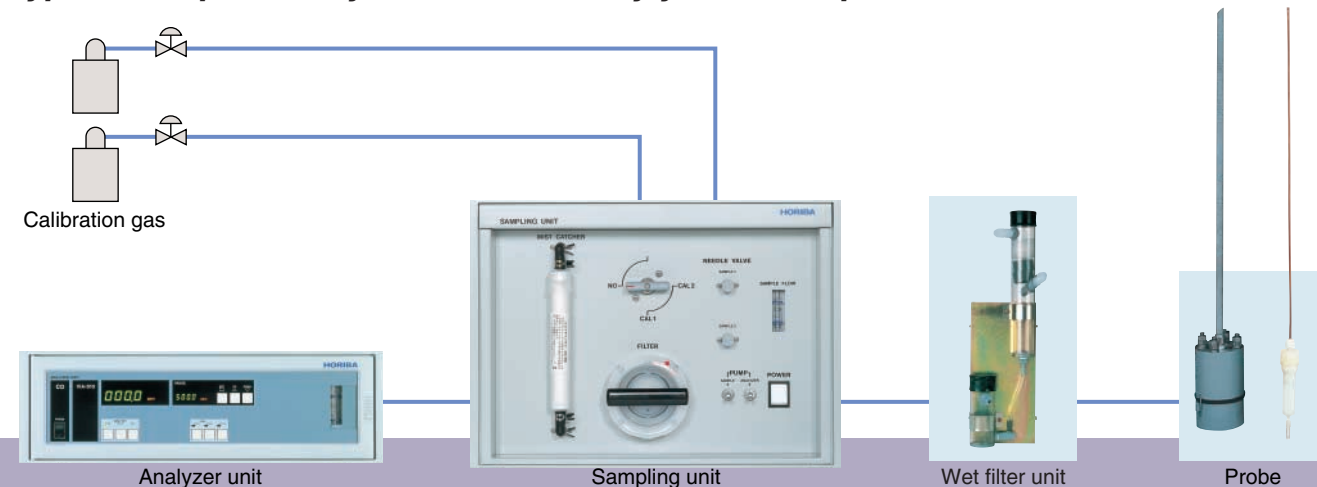

## General Purpose Infrared Gas Analyzer

# VIA-510

**Application:** CO, CO<sub>2</sub>, NO<sub>x</sub>, SO<sub>2</sub>, CH<sub>4</sub>, N<sub>2</sub>O



This double beam infrared analyzer can measure a broad range of gases that absorb infrared energy. Its use of the synchronous rectification method makes the otherwise complex optical adjustment easier to perform. And thanks to the use of linearized coefficients processed by the CPU, linearity is improved to a wider range. The range ratio of 1 : 10 and 4 ranges are standard features, and a ratio of 1 : 20 is optionally available.

## Principle

### Double beam infrared absorptiometry

Infrared energy from the light sources is turned into intermittent light by the rotating chopper, passes through the measurement cells, and then enters the detector. Because part of the infrared energy is absorbed by the sample gas as it passes through the sample cell, the amount of light which enters the detector is different from that coming from the reference cell. The detector is equipped with an infrared filter designed to remove this infrared energy with a wavelength unnecessary for the measurement, and the component to be measured is sealed in the detector under certain conditions. Therefore, the detector detects only the absorption of the infrared energy of the specific wavelength matching the component, and changes in concentration of that component are measured.

The HORIBA <AS> detector\* is equipped with a unique feature for measuring sample gases that contain particularly high levels of interfering substances. In the MAIN detector, the components to be measured plus any interfering substances are detected and in the COMP only the interfering substances are detected and measured, making it possible to compensate for any interference in the sample gas.

\* MAIN and COMP detectors

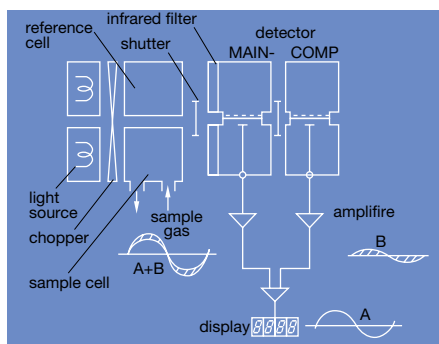

## Measuring range

Components	Standard range		High-sensitivity range
	Min.	Max.	Min.
CO	0 – 100 ppm	0 – 100%	0 – 50 ppm
CO <sub>2</sub>	0 – 100 ppm	0 – 100%	0 – 50 ppm
NO <sub>x</sub>	0 – 200 ppm	0 – 100%	0 – 100 ppm
SO <sub>2</sub>	0 – 100 ppm	0 – 100%	0 – 50 ppm
CH <sub>4</sub>	0 – 100 ppm	0 – 100%	0 – 50 ppm

- Choose the appropriate number of ranges and max. range ratio within the ranges shown above.
- Optional range ratio of 1 : 20 is available.
- High NO<sub>2</sub> concentrations may shorten the life of the NO<sub>x</sub> converter.

## Specifications

**Configuration:** Desk top or 19" panel mount

**Measuring method:** Non-dispersive infrared analysis

**Repeatability:** ±0.5% F.S. (±1.0% F.S. for high-sensitivity range\*)

**Drift:** ±1.0% F.S./day (±2.0% F.S./day for high-sensitivity range\*)

**Response time:** 10 sec. (electrical)

**Ambient conditions:**

Temperature: 0 to 40°C

Humidity: 90% RH or less

**Power:** 100/115/220 V AC (to be specified), 50/60 Hz, 300 VA

**Output signal:** 0 – 1 V DC, 0 – 10 V DC, 0 – 16 or 4 – 20 mA DC, isolated

**No. of ranges:** 4 ranges

**Display:** LED digital display (effective 4 digits)

**Operation gas:** Not needed

**Calibration gas:**

Zero: N<sub>2</sub> or Air

Span: Span gas

**Dimensions:**

430 (w) × 132 (h) × 550 (d) mm

16.9 (w) × 5.2 (h) × 21.7 (d) in

**Weight:** 15 kg, 33 lb

**Sample gas requirements**

Dust: No dust

Mist: Completely removed

Pressure: More than 50 mm H<sub>2</sub>O

Temperature: Ambient temperature

Moisture: 5°C saturation or below

Flow rate: 500 ml /min

Exhaust gas: Discharged at ambient pressure

\* Includes values above the high-sensitivity range but within the minimum standard range.

## Dimensional Outlines

Unit: mm (in)

VIA-510, MPA-510, CLA 510SS

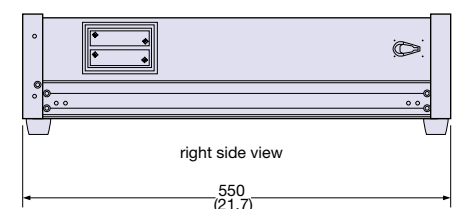
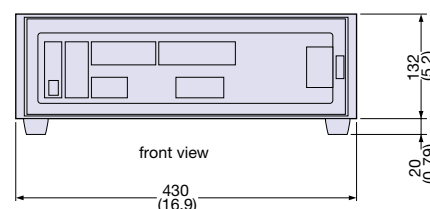

## General Purpose Oxygen Analyzer

# MPA-510

Application: O<sub>2</sub>



This magnetopneumatic oxygen analyzer featuring superior durability, response, and stability, provides data even more reliable than the magnetic dumbbell or polarograph type. Due to the use of N<sub>2</sub> as the operation gas (reference gas), high-sensitivity measurement can be realized free of zero drift. For high-concentration measurement over the 10% range, we also offer a type that uses the ambient air as the operation gas. And, our wide range allows 4 ranges and a range ratio of 1 : 10 as standard, and a ratio of 1 : 20 is optionally available. In addition, the full-scale ranges can be freely changed.

## Principle

### Magnetopneumatic method

When oxygen (a paramagnetic gas) comes into an uneven magnetic field, it is drawn to the stronger side and the pressure rises. This pressure rise can normally be expressed by the following equation.

$$\Delta P = 1/2 H^2 \cdot X \cdot C$$

where H: strength of magnetic field

X: magnetic susceptibility of O<sub>2</sub>

C: concentration of O<sub>2</sub>

A pressure rise is produced outside the field using a non-magnetic gas (nitrogen, etc.), the differential pressure is measured using a condenser microphone, and converted into an electrical signal. A stable signal is produced and transmitted by exciting the magnet intermittently and processing an alternating signal. There will be no signal if there is no O<sub>2</sub> in the sample gas and therefore no zero drift. Highly precise oxygen concentration measurement is possible because the magnetic susceptibility of the sample gas is accurately detected. If a magnetic susceptibility (oxygen) is used as the reference gas, the difference in concentration with the sample gas (oxygen) is taken out as the signal.

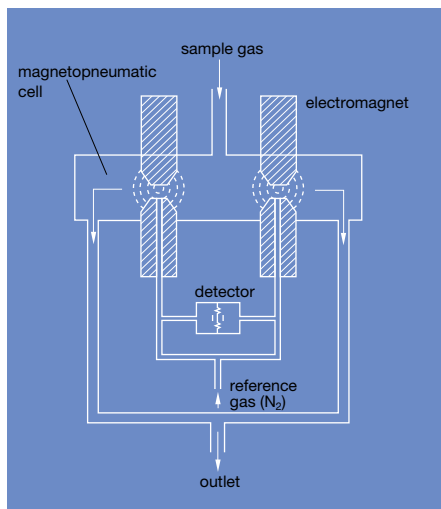

## Flow Schematics

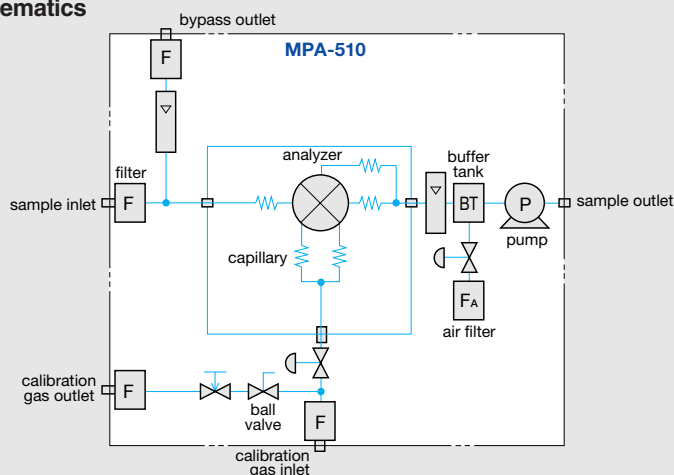

## Measuring range

Components	Standard range		High-sensitivity range	Examples of ranges
	Min.	Max.	Min.	
O <sub>2</sub>	0 - 5%	0 - 100%	0 - 1%	① 5/10/25/50 vol% ② 10/25/50/100 vol%

Choose the appropriate number of ranges and max. range ratio within the ranges shown above. Optional range ratio of 1 : 20 is available.

## Specifications

**Configuration:** Desk top or 19" panel mount

**Measuring method:** Magnetopneumatic analysis

**Repeatability:** ±0.5% F.S. (±1.0% F.S. for high-sensitivity range\*)

**Drift:** ±1.0% F.S./day (±2.0% F.S./day for high-sensitivity range\*)

**Response time:** 10 sec. (electrical)

**Ambient conditions:**

Temperature: 0 to 40°C

Humidity: 90% RH or less

**Power:** 100/115/220 V AC (to be specified), 50/60 Hz, 100 VA

**Output signal:** 0 - 1 V DC, 0 - 10 V DC, 0 - 16 or 4 - 20 mA DC, isolated

**No. of ranges:** 4 ranges

**Display:** LED digital display (effective 4 digits)

**Operation gas\*\*:**

N<sub>2</sub> (for types with 5% or smaller range)

Flow rate: 6 ml/min

**Calibration gas:**

Zero: N<sub>2</sub>

Span: Span gas or Air

**Dimensions:**

430 (w) × 132 (h) × 550 (d) mm

16.9 (w) × 5.2 (h) × 21.7 (d) in

**Weight:** 15 kg, 33 lb

**Sample gas requirements**

Dust: No dust

Mist: Completely removed

Pressure: More than 50 mm H<sub>2</sub>O

Temperature: Ambient temperature

Moisture: 5°C saturation or below

Flow rate: 500 ml/min

Exhaust gas: Discharged at ambient pressure

\* Includes values above the high-sensitivity range but within the minimum standard range.

\*\* For measurement in the 10% range and above, specify if you need the type that does not need operation gas.

## General Purpose Nitrogen Oxides Analyzer

# CLA-510SS

Application: NOx



A nitrogen oxides analyzer based on the atmospheric pressure chemiluminescence method.

A drier unit equipped with automatic reseasonation is provided as a standard feature, so ambient air can be used as the source of O<sub>3</sub>. There is no need to supply an auxiliary gas. As another standard feature, it provides 7 ranges and a range ratio of 1 : 100 (e.g. 0 – 20/50/100/1000/2000 ppm), making it easy to handle a wide variety of applications. When combined with the ES-C510SS sampling unit, both NO and NOx can be measured.

## Principle

### Atmospheric pressure chemiluminescence method

The chemiluminescence method utilizes the reaction of NO and O<sub>3</sub>.

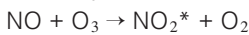
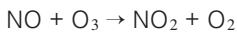

Some of the NO<sub>2</sub> generated in this reaction turns into NO<sub>2</sub> in the excited state, then emits chemiluminescence of 600 to 3000 nm when it returns to NO<sub>2</sub> in the normal state. Because the degree of luminescence is proportional to the amount of NO molecules, the concentration of NO in the sample gas can be determined by measuring the intensity of this light. The detector, provided with a semiconductor sensor, detects the luminescence, then amplifies it and outputs it as an electric signal. Thanks to the use of the semiconductor sensor, the detector is more compact, maintenance is easier, and service life is longer. To measure NOx (NO + NO<sub>2</sub>), the NO<sub>2</sub> is turned into NO by the reduction converter.

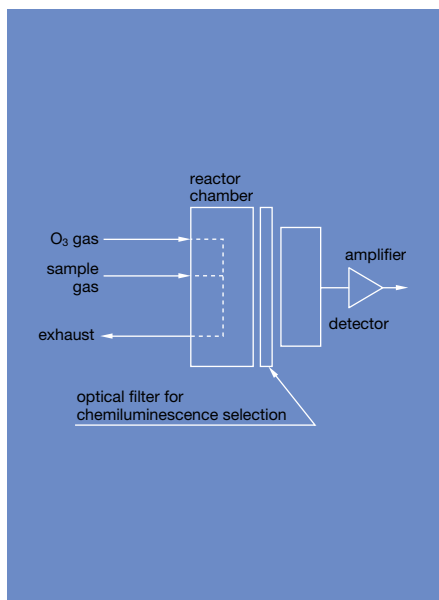

## Flow Schematics

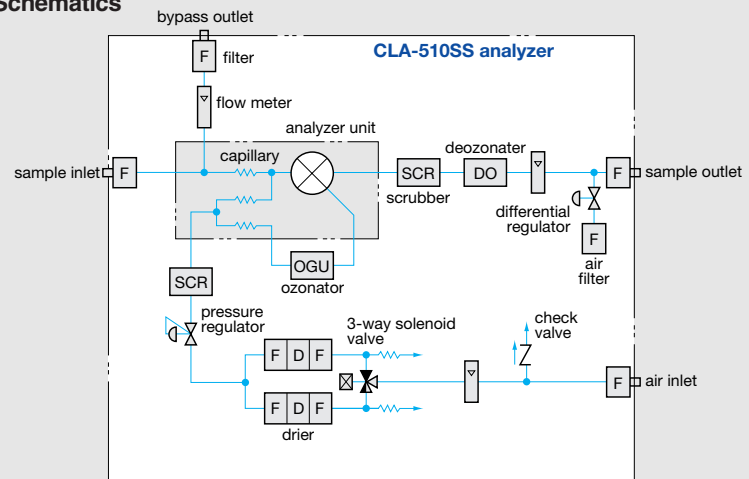

## Measuring range

Components	Standard range		High-sensitivity range	Examples of ranges
	Min.	Max.	Min.	
NOx	0 – 100 ppm	0 – 5000 ppm	0 – 20 ppm	① 0 – 20/50/100/200/500/1000/2000 ppm ② 0 – 25/50/100/250/500/1000/2500 ppm

- Choose the appropriate number of ranges and max. range ratio within the ranges shown above.
- Please consult us for higher sensitivity range (e.g. 0-1 ppm)
- Sample gas should be free of O<sub>2</sub> for ranges over 2000 ppm.
- High NO<sub>2</sub> concentrations may shorten the life of the NOx converter.

## Specifications

**Configuration:** Desk top or 19" panel mount

**Measuring method:** Chemiluminescence

**Repeatability:** ±0.5% F.S. (±1.0% F.S. for high-sensitivity range\*)

**Drift:** ±1.0% F.S./day (±2.0% F.S./day for high-sensitivity range\*)

**Response time:** 10 sec. (electrical)

**Ambient conditions:**

Temperature: 0 to 40°C

Humidity: 90% RH or less

**Power:** 100/115/220 V AC (to be specified), 50/60 Hz, 300 VA

**Output signal:** 0 – 1 V DC, 0 – 10 V DC, 0 – 16 or 4 – 20 mA DC, isolated

**No. of ranges:** 7 ranges

**Display:** LED digital display (effective 4 digits)

**Operation gas:** Not needed (ambient air used)

**Calibration gas:**

Zero: N<sub>2</sub> or Air

Span: Span gas

**Dimensions:**

430 (w) × 132 (h) × 550 (d) mm

16.9 (w) × 5.2 (h) × 21.7 (d) in

**Weight:** 20 kg, 44 lb

**Sample gas requirements**

Dust: No dust

Mist: Completely removed

Pressure: More than 50 mm H<sub>2</sub>O

Temperature: Ambient temperature

Moisture: 5°C saturation or below

Flow rate: 500 ml/min

Exhaust gas: Discharged at ambient pressure

\* Includes values above the high-sensitivity range but within the minimum standard range.

## General Purpose Total Hydrocarbon Analyzer

# FIA-510

Application: THC



Employs the hydrogen flame ionization detection method featuring superb response characteristics and stability. Allows highly sensitive and highly precise continuous measurement.

Measurement can be performed in 7 ranges and in a range ratio of 0 to 10/30,000 ppmC, making it possible to satisfy a wide variety of applications. As the sampling unit, we recommend the ES-F510. If the ES-F510 is not used, a sampling pump and a buffer tank (both optional) are necessary.

## Principle

### Hydrogen flame ionization detection method

The hydrogen flame ionization detection (FID) method utilizes the ionization caused by the high-temperature combustion at the tip of the burner jet when organic carbon compounds are introduced into the hydrogen flame. Two electrodes are separated in a hydrogen flame. When a DC voltage is applied between the two electrodes, a trace ionization current, that is proportional to the number of carbon molecules in the hydrocarbon, runs between them. This current is converted into a voltage by means of high impedance amplifier to measure total hydrocarbon.

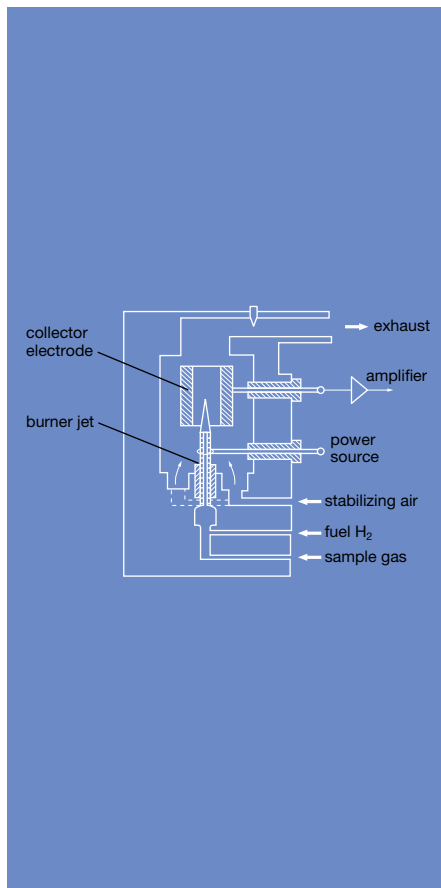

## Flow Schematics

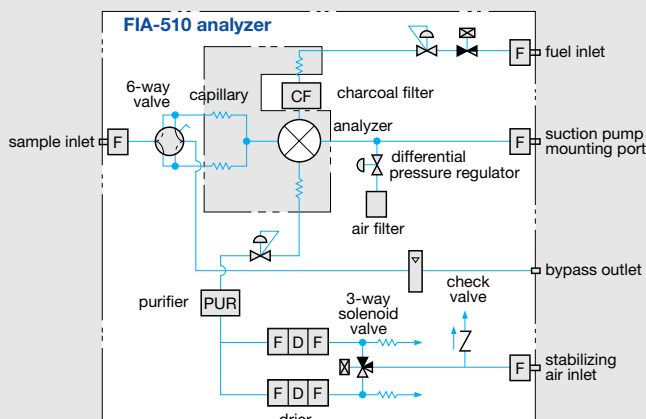

## Measuring range

Components	Standard range		High-sensitivity range	Examples of ranges
	Min.	Max.	Min.	
THC	0 - 50 ppm C	0 - 3% C	0 - 10 ppm C	① 0 - 10/50/100/500/1000/5000/10000 ppmC ② 0 - 20/50/100/200/500/1000/2000 ppmC

Choose the appropriate number of ranges and max. range ratio within the ranges shown above.

## Specifications

**Configuration:** Desk top or 19" panel mount

### Measuring method:

Hydrogen flame ionization detection

**Repeatability:**  $\pm 0.5\%$  F.S. ( $\pm 1.0\%$  F.S. for high-sensitivity range\*)

**Drift:**  $\pm 1.0\%$  F.S./day ( $\pm 2.0\%$  F.S./day for high-sensitivity range\*)

**Response time:** 10 sec. (electrical)

### Ambient conditions:

Temperature: 0 to 40°C

Humidity: 90% RH or less

**Power:** 100/115/220 V AC (to be specified), 50/60 Hz, 500 VA

**Output signal:** 0 - 1 V DC, 0 - 10 V DC, 0 - 16 or 4 - 20 mA DC, isolated

**No. of ranges:** 7 ranges

**Display:** LED digital display (effective 4 digits)

**Operation gas:** Combustion gas should be specified; pure H<sub>2</sub> (flow rate: about

30 ml /min.) or 40% H<sub>2</sub>/He (flow rate: about 120ml /min.)

### Calibration gas:

Zero: N<sub>2</sub> or Air

Span: Span gas

### Dimensions:

430 (w) × 132 (h) × 550 (d) mm

16.9 (w) × 5.2 (h) × 21.7 (d) in

**Weight:** 20 kg, 44 lb

### Sample gas requirements

Dust: No dust

Mist: Completely removed

Pressure: More than 50 mm H<sub>2</sub>O

Temperature: Ambient temperature

Moisture: 5°C saturation or below

Flow rate: 500 ml /min

Exhaust gas: Discharged at ambient pressure

\* Includes values above the high-sensitivity range but within the minimum standard range.

# ES-510, ES-C510SS, ES-F510

Fitted with drain separators, mist catchers, dehumidifiers, filters, pumps, flow rate regulators, sample calibration line change-over valves, and NO<sub>x</sub>-NO measuring line change-over valves (ES-C510SS).

Can even measure samples with such tough characteristics as high temperature, high dust content, and high moisture.



## Flow Schematics

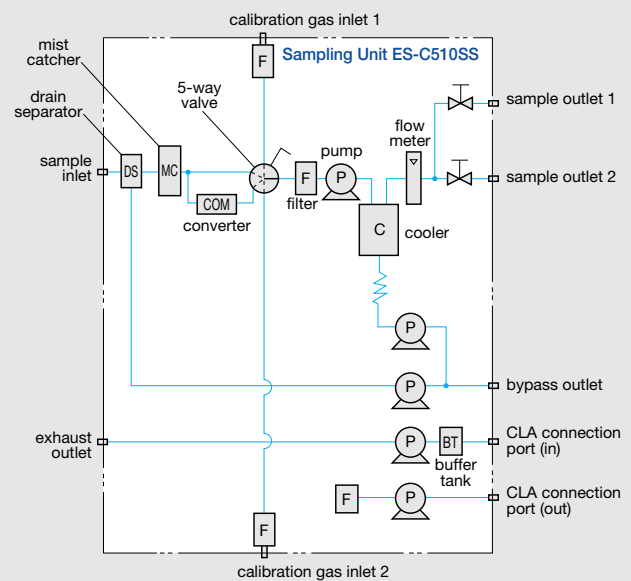
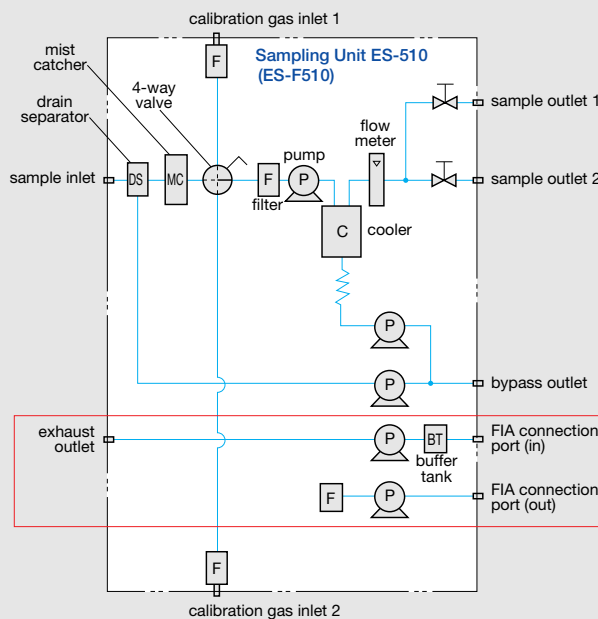

## Specifications

### Applicable models:

ES-510: VIA-510 and MPA-510

ES-C510SS: CLA-510SS (VIA-510 and MPA-510 also possible)

ES-F510: FIA-510 (VIA-510 and MPA-510 also possible)

**Configuration:** 19"; analyzer may be stacked on

**Sampling method:** 5°C dry sampling (ES-C510SS fitted with the NO<sub>x</sub> → NO converter)

**Materials in contact with sample gas:** SUS, PVC, Teflon, Viton, glass

**Sampling volume:** 3 – 4 l /min

**Sample feed rate:** 500 ml /min (1 system) × 2

**Power:** 100/115/220 V AC (to be specified), 50/60 Hz, 300 VA

**Dimensions:** 430 (w) × 309 (h) × 550 (d) mm  
16.9 (w) × 12.2 (h) × 21.7 (d) in

**Weight:** Approx. 20 kg, 44 lb

### Fittings:

**Sample inlet:** PT 1/4 female (φ 8/6 Teflon joint)

**Sample outlet:** PT 1/4 female (φ 6/4 Teflon joint) × 2

**Calibration gas inlet:** PT 1/4 female (φ 6/4 Teflon joint) × 2

**Bypass outlet:** PT 1/4 female (φ 8/6 hose end)

### CLA inlet:

ES-510: None

ES-C510SS, ES-F510: PT 1/4 female (φ 6/4 Teflon joint) × 2

### Sample gas requirements:

**Temperature:** Ambient temp. of place of installation

**Dust:** 1 mg/Nm<sup>3</sup> or less

**Moisture:** Ambient humidity saturation or less

**Pressure:** Ambient pressure ±100 mm H<sub>2</sub>O

**Others:** There should be no corrosive gas or other gases that react with gas to be measured.

Note: For VIA-510 (NO<sub>x</sub> analyzer), use the ES-C510SS sampling unit.  
With the ES-510, NO measurement only is possible.

**HORIBA continues contributing  
to the preservation of the global  
environment through analysis  
and measuring technology.**



**Please read the operation manual before using this product to assure safe and proper handling of the product.**

- The contents of this catalog are subject to change without prior notice, and without any subsequent liability to this company.
- The color of the actual products may differ from the color pictured in this catalog due to printing limitations.
- It is strictly forbidden to copy the content of this catalog in part or in full.
- All brand names, product names and service names in this catalog are trademarks or registered trademarks of their respective companies.

<http://www.horiba.com> e-mail: [info@horiba.co.jp](mailto:info@horiba.co.jp)

● **HORIBA, Ltd.**

**Head Office**  
Miyano Higashi, Kisshoin  
Minami-ku, Kyoto, Japan  
Phone: 81 (75) 313-8123  
Fax: 81 (75) 321-5725

**Tokyo Sales Office**  
1-7-8 Higashi-Kanda  
Chiyoda-ku, Tokyo, Japan  
Phone: 81 (3) 3861-8231  
Fax: 81 (3) 3861-8259

● **HORIBA TRADING (SHANGHAI) CO., Ltd.**

**Shanghai Office**  
Room 1701, United Plaza,  
1468 Nanjing Rd. West,  
Shanghai, 200040, China  
Phone: 21-6289-6060  
Fax: 21-6289-5553

**Beijing Office**  
Room 1801, Capital Tower Beijing,  
Tower 1 No.6Jia, Jianguomenwai Ave.,  
Chaoyang District, Beijing,  
100022 China  
Phone: 10-8567-9966  
Fax: 10-8567-9066

● **HORIBA KOREA Ltd.**

112-6 Sogong-Dong  
Choong-ku, Seoul, Korea  
Phone: 82 (2) 753-7911  
Fax: 82 (2) 756-4972

● **HORIBA INSTRUMENTS  
Pte. LTD.**

10 Ubi Crescent  
#05-11/12, Ubi Techpark  
Singapore 408564  
Phone: 65 6745-8300  
Fax: 65 6745-8155

● **HORIBA India Private Limited**

**Delhi Office**  
1212A, Hemkunt Tower,  
98 Nehru Place,  
New Delhi - 110019 INDIA  
Phone: +91 11-4669-5001/5002

**Pune Office**  
502, Purushottam Plaza,  
Baner Road, Baner,  
Pune - 411045 INDIA  
Phone: +91 20-2729-1121

● **HORIBA INSTRUMENTS  
INCORPORATED**

**Irvine Facility**  
17671 Armstrong Avenue  
Irvine, CA 92614, U.S.A.  
Phone: 1 (949) 250-4811  
Fax: 1 (949) 250-0924

● **HORIBA INSTRUMENTS  
LIMITED**

Kyoto Close  
Summerhouse Road  
Moulton Park, Northampton  
NN3 6FL, U.K.  
Phone: 44 (1604) 542500  
Fax: 44 (1604) 542699

● **HORIBA GmbH**

Kaplanstrasse 5  
A-3430 Tulln,  
Austria  
Phone: 43 (2272) 65225  
Fax: 43 (2272) 65230

**HORIBA CZECHIA**  
Organizacni slozka Praha  
Petrohradská 13  
CZ-101 00 Praha 10,  
Czech Republic  
Phone: 420 (2) 717-464-80  
Fax: 420 (2) 717-470-64

● **HORIBA EUROPE GmbH**

**Head Office**  
Hans-Mess-Str.6  
D-61440 Oberursel/Ts.  
Germany  
Phone: 49 (6172) 1396-0  
Fax: 49 (6172) 137385

**Leichlingen Facility**  
Julius-kronenberg Strasse  
D-42799 Leichlingen  
Germany  
Phone: 49 (2175) 8978-0  
Fax: 49 (2175) 8978-50

● **HORIBA FRANCE**

12, Avenue des Tropiques  
91955 LES ULIS  
France  
Phone: 33 (1) 69-29-96-23  
Fax: 33 (1) 69-29-95-77

Bulletin:HRE-2836G

Printed in Japan ZK-R(SK)23